

KC9806E/S/P

Digital Servo Motor Controller

Preliminary
Rev.0.02
Feb.21.2011

Description

KC9806X is a Application Specific Integrated Circuit with wide voltage scope and simple peripheral circuit used in digital servo control. It has 4 PWM output control interfaces and the drive H-Bridge.

Features

- Directly drive MOSFET H-Bridge
- Parameters set through PC or configuration card.
- Following parameters can be set: Dead band, pulse width step size, gain, Max PWM duty cycle, middle point position and the signal recognition range.
- Selectable clock frequencies: 5MHz, 10MHz or 20MHz.
- Internal high precision oscillator $\pm 1.5\%$ (KC9806P)
- Small outline TSSOP20 and QFN24

Applications

- For radio control
- For servo motor control

Recommended Operating Conditions

- Supply voltage range: 3.0 to 12 V (KC9806S/P) 2.8 to 12 V (KC9806E)
- Operating temperature: -20 to 75°C

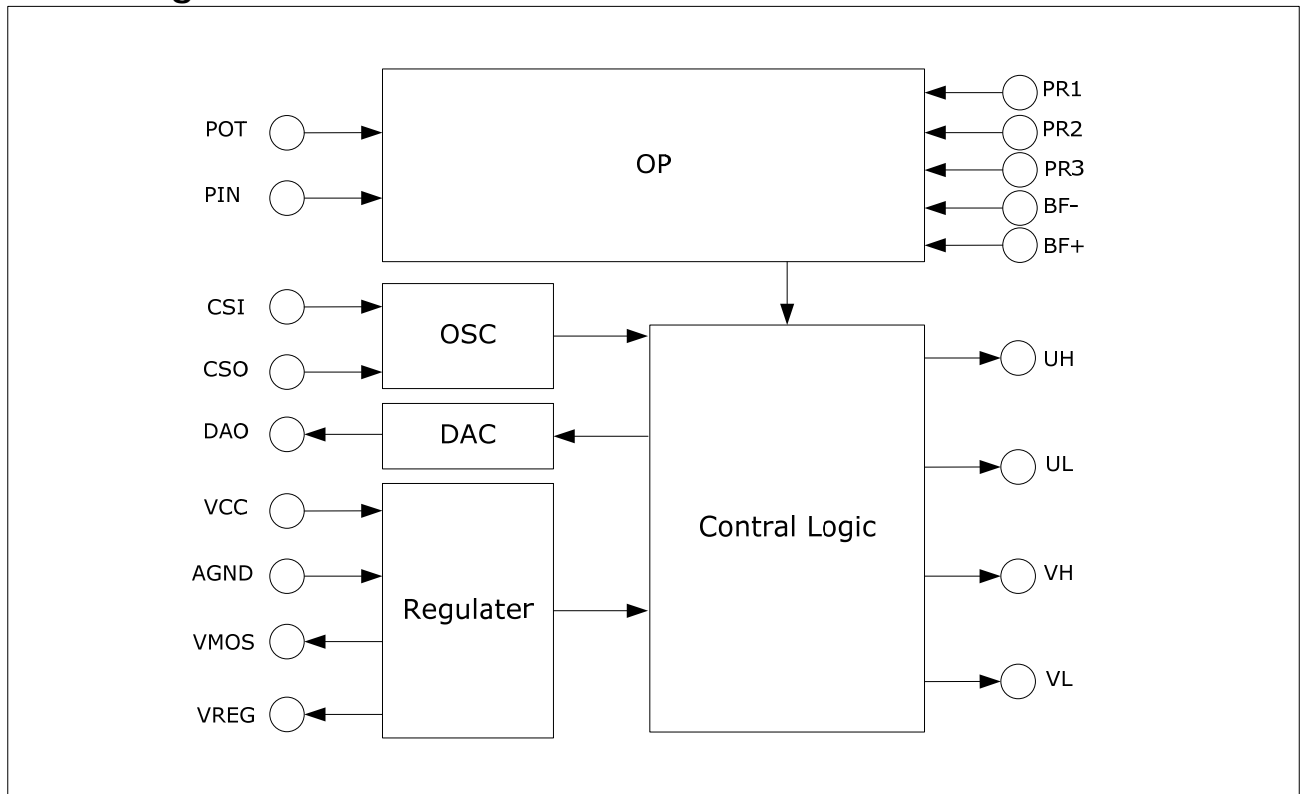

Block Diagram

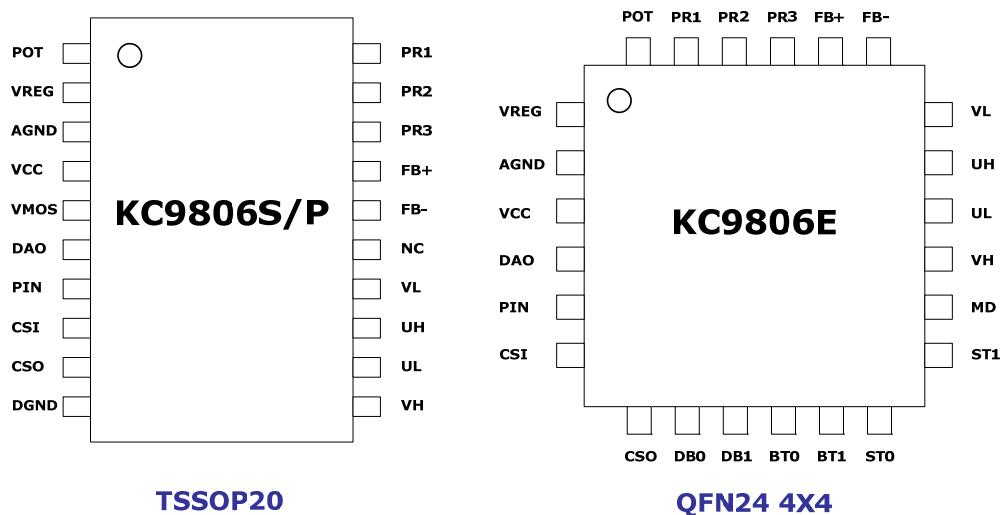

Pin Arrangement



Pin Description

Symbol	Function	Notes
AGND	System Analog Ground	Connect system ground
DGND	System Digital Ground	Connect system ground
VCC	Supply voltage	Connect the Electrolytic condenser more than 10 uF and the ceramics condenser more than 0.1 uF.
VREG	Regulated voltage output	Connect to Potentiometer with a 100nF filter capacitor
VMOS	Regulated voltage output	Connect to 100nF capacitor for the filter of VMOS
DAO	D/A converter output 	Connect to 15nF capacitor for the filter of DAO
PIN	Receiving pulse input 	Control and configuration Signal input terminal of servo
POT	Servo position voltage input	Connected with central tap of potentiometer
BF+	Damping resistor input+	Connect to the damping resistor of 50 k Ω - 1 M Ω .
BF-	Damping resistor input-	Connect to the damping resistor of 50 k Ω - 1 M Ω .
PR1	SERVO voltage gain regulation pin 1	Connected to resistor for gain regulation
PR2	SERVO voltage gain regulation pin 2	
PR3	SERVO voltage gain regulation pin 3	
CSI	Oscillation terminal input	Connect to resonator
CSO	Oscillation terminal output	
UH	Output pin 1	Connected with gate of MOSFET H-Bridge
UL	Output pin 2	
VH	Output pin 3	
VL	Output pin 4	
NC	Not connect	

DC Electrical Characteristics **Ta=25°C**

Parameters	Conditions	Min	Typical	Max	Unit
Power Supply Voltage		2.8		12	V
Supply Current 1	Clock frequency 5 MHz		11	15	mA
Supply Current 2	Clock frequency 20 MHz		21	25	mA
Regulated power supply		2.4	2.5	2.6	V
Supply Voltage dependence of Vreg	VCC=3~12V		0.1		%/V
PWM frequency	Clock frequency 5 MHz		305		Hz

Attention Electrostatic protection!

Typical Application

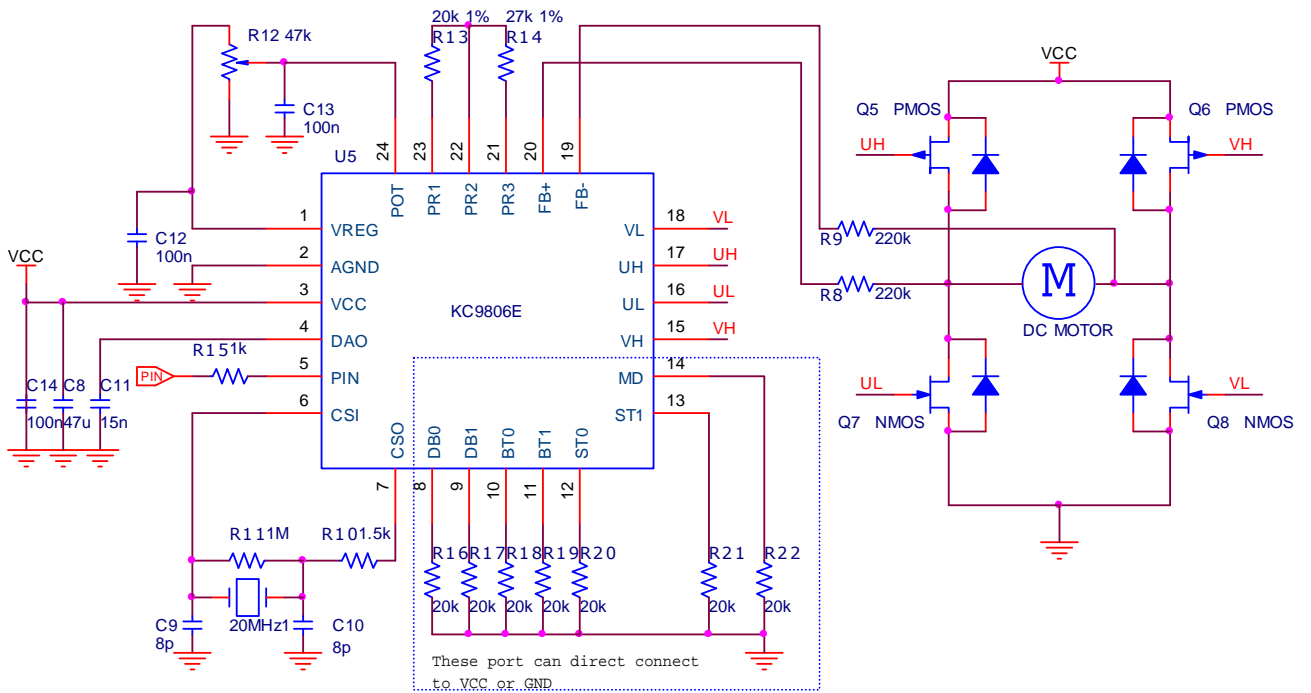
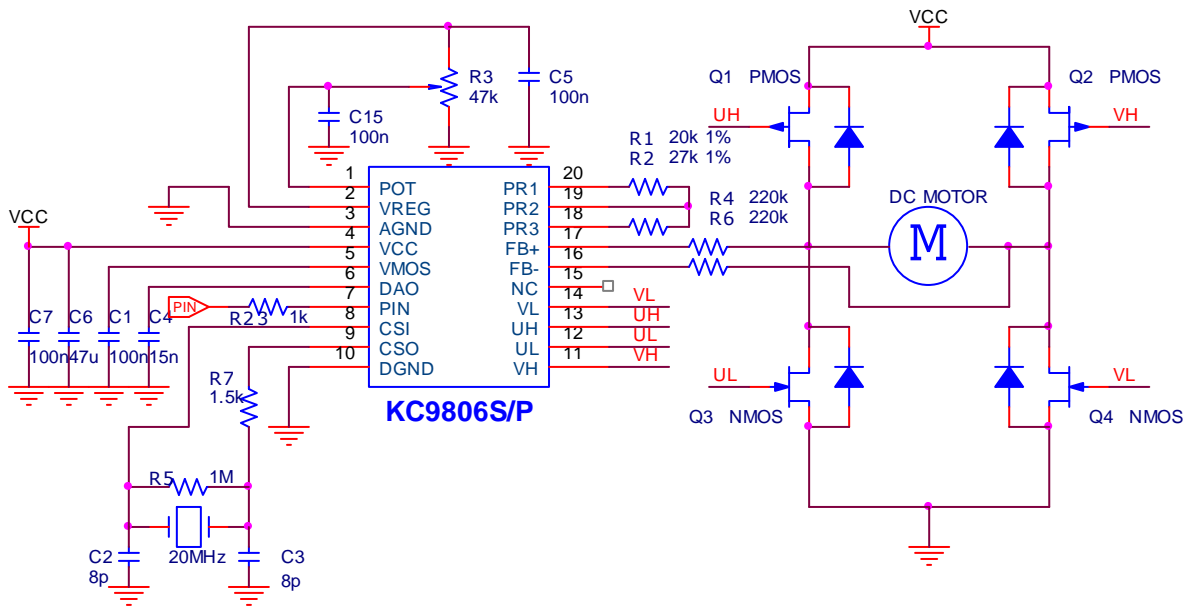

TSSOP20(173mil) PACKAGE OUTLINE DIMENSIONS

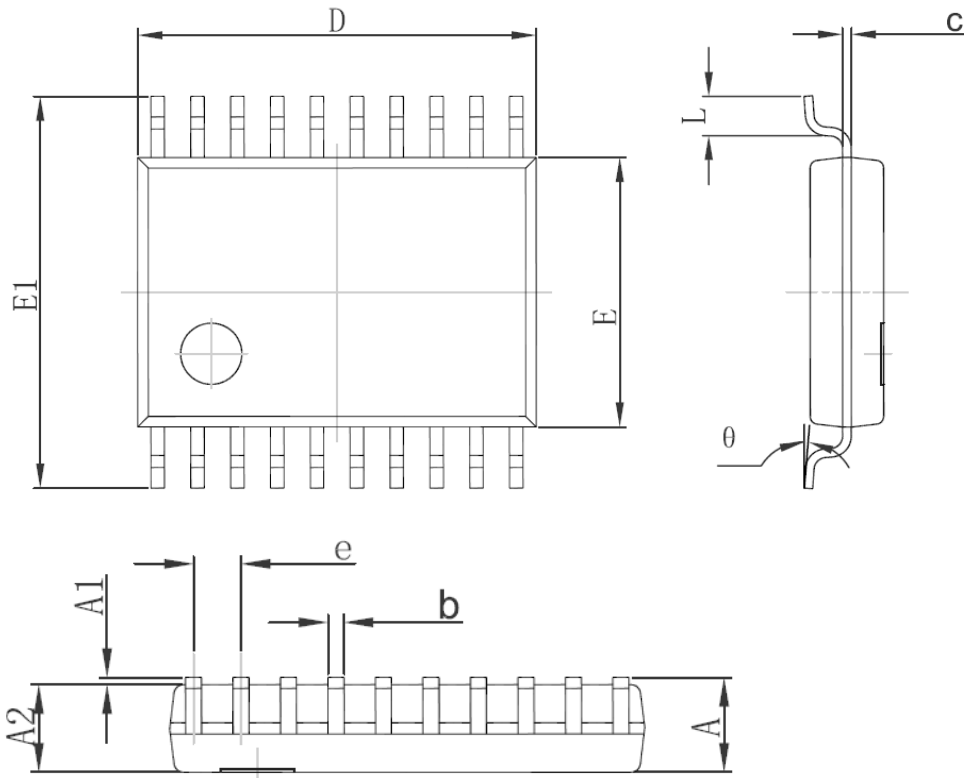

Symbol	Dimensions In Millimeters		Dimensions In Inches	
	Min	Max	Min	Max
A		1.450		0.057
A1	0.050	0.200	0.002	0.008
A2	1.150	1.250	0.045	0.049
b	0.200	0.310	0.008	0.013
c	0.090	0.200	0.004	0.008
D	6.300	6.700	0.248	0.264
E	4.300	4.500	0.169	0.177
E1	6.200	6.600	0.244	0.260
E	0.65BSC		0.026BSC	
L	0.450	0.750	0.018	0.030
theta	0°	8°	0°	8°

QFN24 4X4 PACKAGE OUTLINE DIMENSIONS

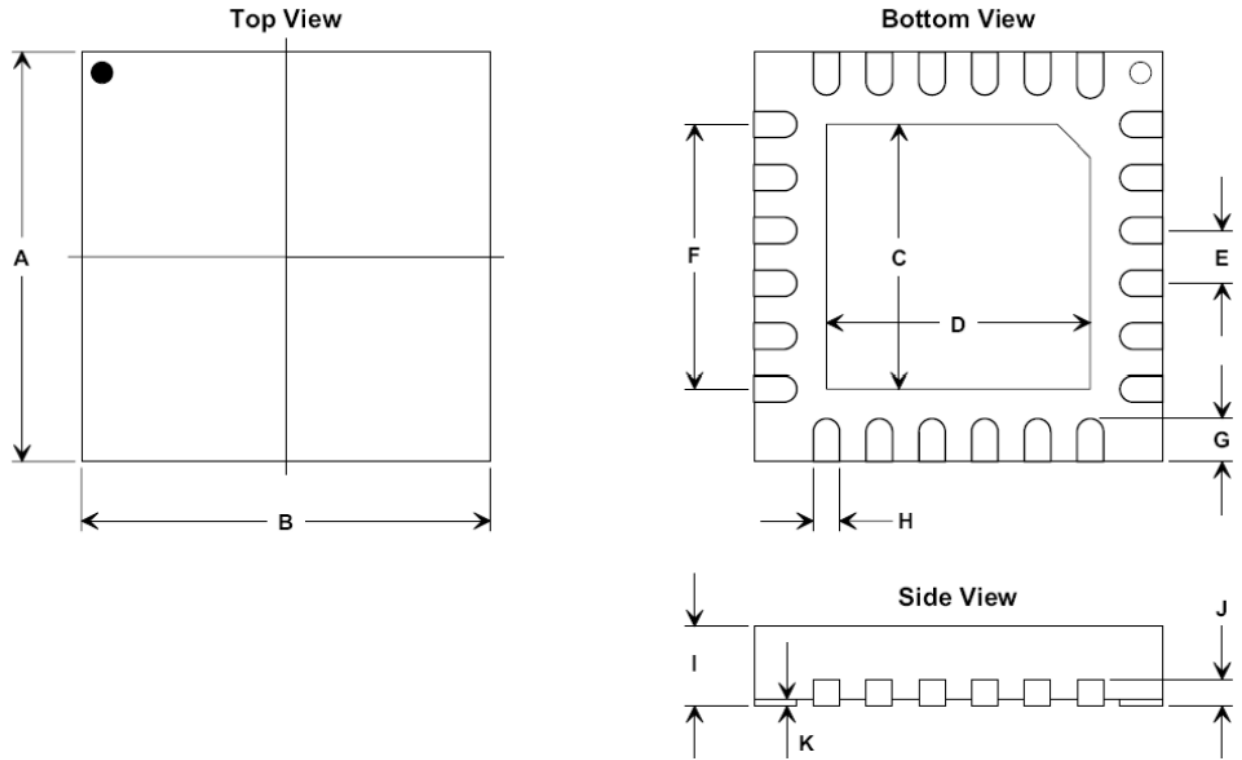

Symbol	Dimensions In Millimeters		Dimensions In Inches	
	Min	Max	Min	Max
A	3.900	4.100	0.154	0.161
B	3.900	4.100	0.154	0.161
C	2.550	2.750	0.100	0.108
D	2.550	2.750	0.100	0.108
E	0.500	0.500	0.020	0.020
F	2.540	2.540	0.100	0.100
G	0.350	0.550	0.014	0.022
H	0.180	0.280	0.007	0.011
I	0.800	1.000	0.028	0.031
J	0.195	0.211	0.008	0.008
K	0.000	0.050	0.000	0.002